

## Description

The Schottky diodes employ a wide bandgap Gallium Nitride (GaN) material that ensures a 650 V rating. The diodes show no recovery at turn-off with negligible ringing patterns. Their minimal capacitive turn-off behavior is independent of temperature. The superior switching performance of GaN Schottky diodes improves system efficiency as compared to Silicon diodes.

## Features and benefits

- ◆ Reduces conduction losses by lower  $V_F$  during extreme light load conditions
- ◆ Reduces switching losses in commutation between diodes and associated MOSFETs
- ◆ Lower EMI than FRD & SiC due to the higher softness factor( $T_s$ ) known as a soft-recovery
- ◆ Extremely fast switching, temperature independent, no thermal runaway issue, better thermal conductivity due to lower  $R_{\theta JC}$
- ◆ Positive temperature coefficient on  $V_F$ , suitable for parallel commutation configuration in high power
- ◆ System cost and size savings due to the reduced cooling and EMI requirements

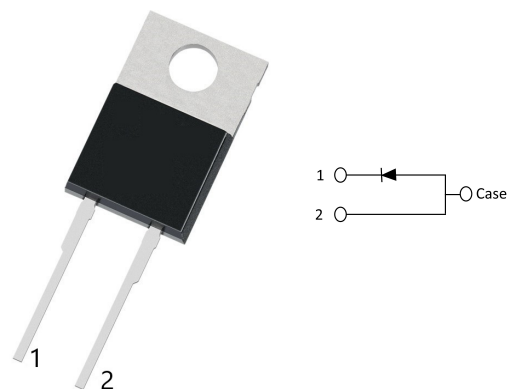

Part Number	Package	Marking
NT1D10565T	TO-220-2L	1D10565

## Applications

- ◆ Power factor correction modules
- ◆ Secondary side rectification
- ◆ Anti-Parallel Diode ( Switchmode Power Supply, Inverters )
- ◆ Free Wheeling Diode ( Motor Controllers, Converters, Inverters )
- ◆ Snubber Diode

## Maximum Ratings ( $T_J = 25^\circ\text{C}$ unless otherwise specified)

Parameter	Symbol	Test Conditions	Value	Units
DC Peak reverse voltage	$V_R$		650	V
Repetitive peak reverse voltage	$V_{RRM}$		650	V
Surge peak reverse voltage	$V_{RSM}$		650	V
Continuous forward current	$I_F$	$T_C = 125^\circ\text{C}$	5	A
Non-repetitive forward surge current sine halfwave	$I_{FSM}$	$T_C = 25^\circ\text{C}, t_p = 10\text{ms}$	20	A
		$T_C = 125^\circ\text{C}, t_p = 10\text{ms}$	15	
Power dissipation	$P_{Tot}$	$T_C = 25^\circ\text{C}$	69	W
		$T_C = 125^\circ\text{C}$	13	
Maximum junction temperature	$T_{J,max}$		150	$^\circ\text{C}$
Operating and storage temperature	$T_J, T_{STG}$		-55 to 150	$^\circ\text{C}$
Soldering temperatures, wavesoldering only allowed at leads	$T_{sold}$	1.6mm from case for 10s	260	$^\circ\text{C}$

**Electrical Characteristics** ( $T_J = 25^\circ\text{C}$  unless otherwise specified)

Parameter	Symbol	Test Conditions	Value			Units
			Min	Typ	Max	
Forward voltage	$V_F$	$I_F=100\text{mA}, T_J=25^\circ\text{C}$		0.55		V
		$I_F=5\text{A}, T_J=25^\circ\text{C}$		1.55	1.75	
		$I_F=5\text{A}, T_J=150^\circ\text{C}$		2.15	2.35	
Reverse current	$I_R$	$V_R=650\text{V}, T_J=25^\circ\text{C}$		5		$\mu\text{A}$
		$V_R=650\text{V}, T_J=150^\circ\text{C}$		100		
Total capacitive charge <sup>(1)</sup>	$Q_C$	$V_R=400\text{V}$ $di/dt=300\text{A}/\mu\text{s}$		21		nC
Total capacitance	C	$V_R=1\text{V}, f=1\text{MHz}$		450		pF
		$V_R=300\text{V}, f=1\text{MHz}$		45		
		$V_R=600\text{V}, f=1\text{MHz}$		30		
Softness Factor (tb/ta)	$T_S$	$V_R=400\text{V}$ $di/dt=300\text{A}/\mu\text{s}$		7.0		

(1)  $Q_C$  is independent on  $T_J$ ,  $di_F/dt$ , and  $I_F$  as shown in the application note

**Thermal characteristics**

Parameter	Symbol	Test Conditions	Value			Units
			Min	Typ	Max	
Thermal resistance, junction - case	$R_{\theta JC}$			1.8		$^\circ\text{C}/\text{W}$

**Typical Performance**

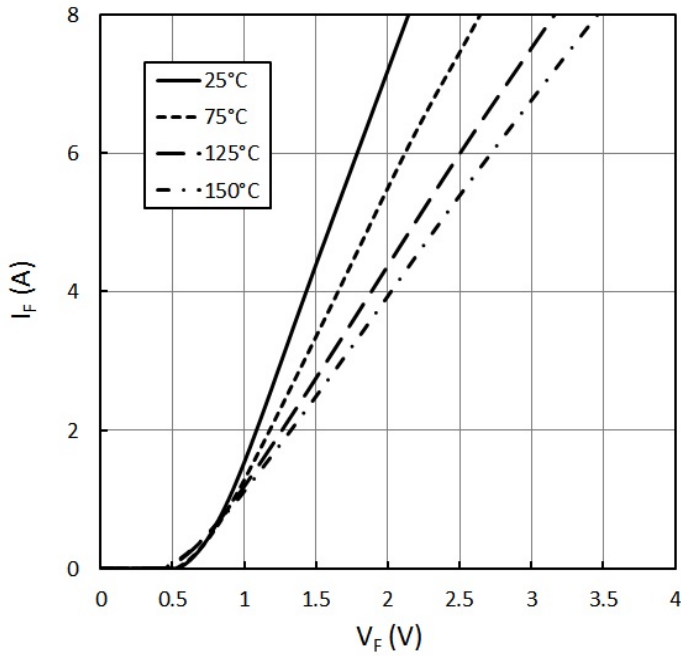

**Figure 1 Typical forward characteristics**

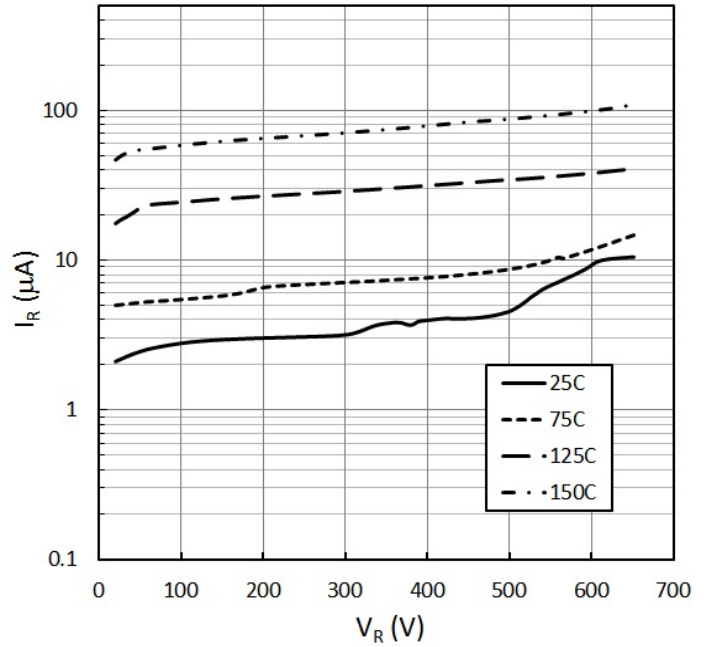

**Figure 2 Typical reverse characteristics**

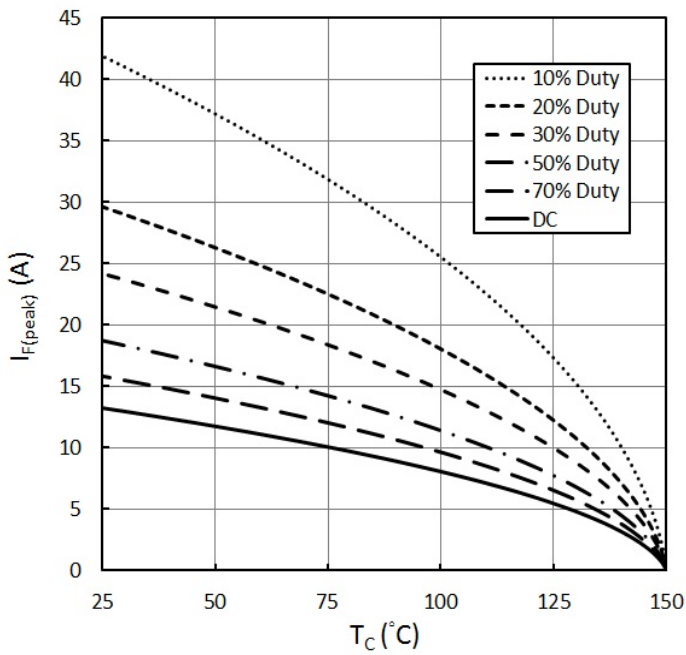

**Figure 3 Current Derating**

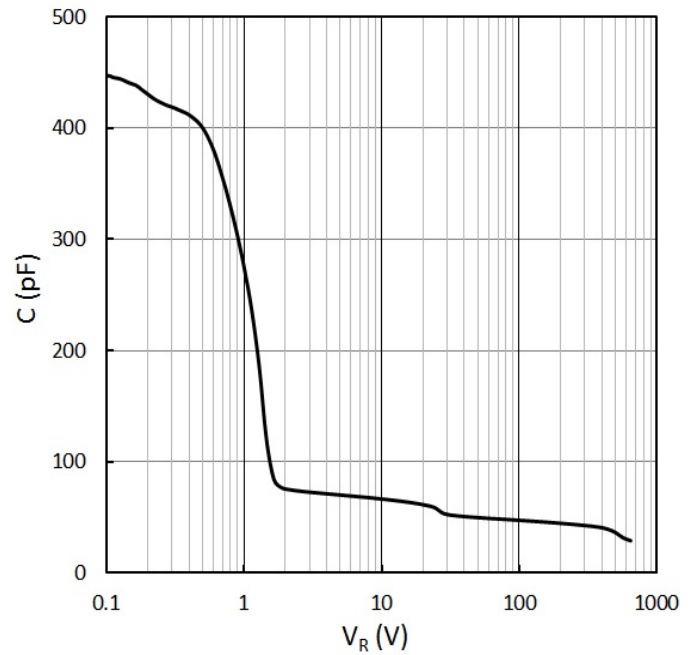

**Figure 4 Capacitance vs. reverse voltage at 1MHz**

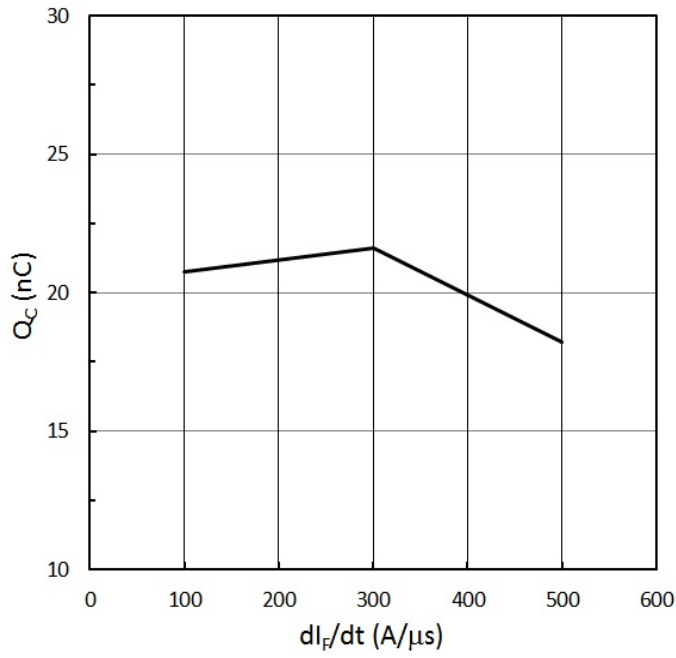

**Figure 5 Capacitance charge vs. current slope**

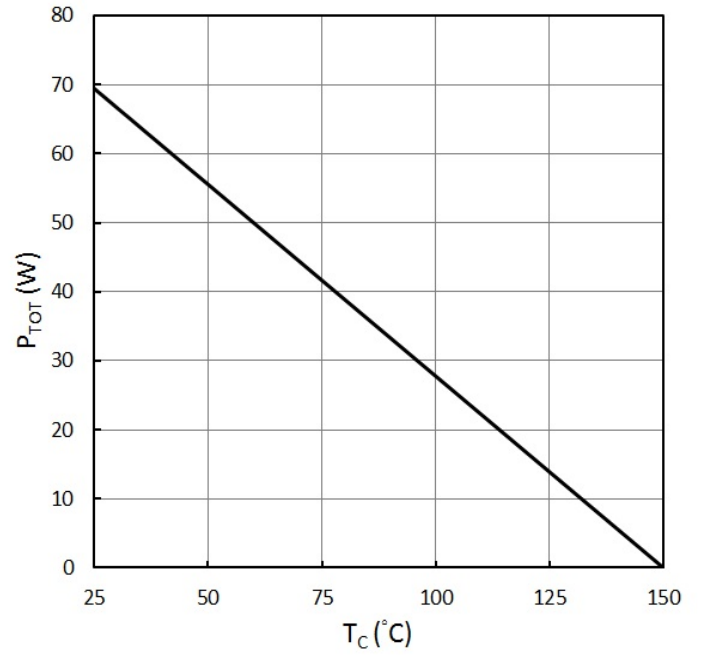

**Figure 6 Power dissipation**

Package information

TO-220-2L dimensions in mm

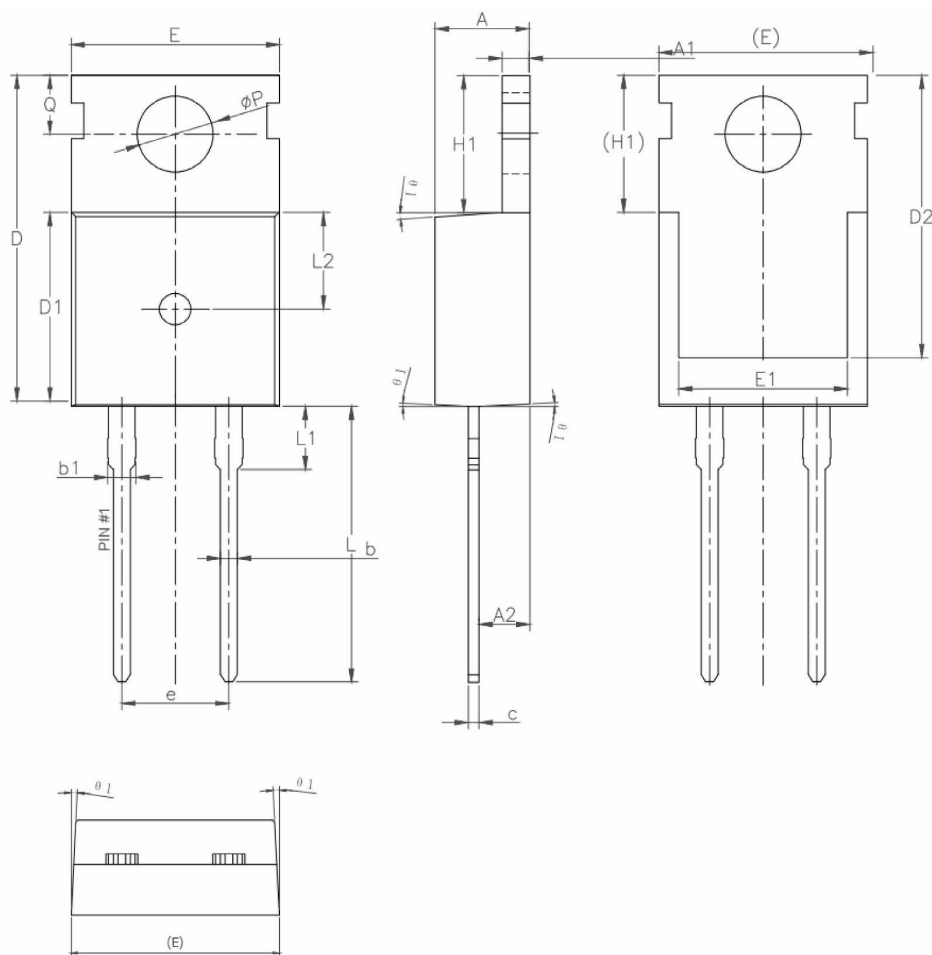

SYMBOL	MIN	NOM	MAX
A	4.40	4.50	4.60
A1	1.27	1.30	1.33
A2	2.30	2.40	2.50
b	0.70	—	0.90
b1	—	—	1.40
c	0.45	0.50	0.60
D	15.30	15.70	16.10
D1	9.10	9.20	9.30
D2	13.10	—	13.70
E	9.70	9.90	10.20
E1	7.80	8.00	8.20
e	5.08BSC		
H1	6.30	6.50	6.70
L	12.78	13.08	13.38
L1	—	—	3.50
L2	4.60REF		
øP	3.55	3.60	3.65
Q	2.73	—	2.87
theta 1	1°	3°	5°